

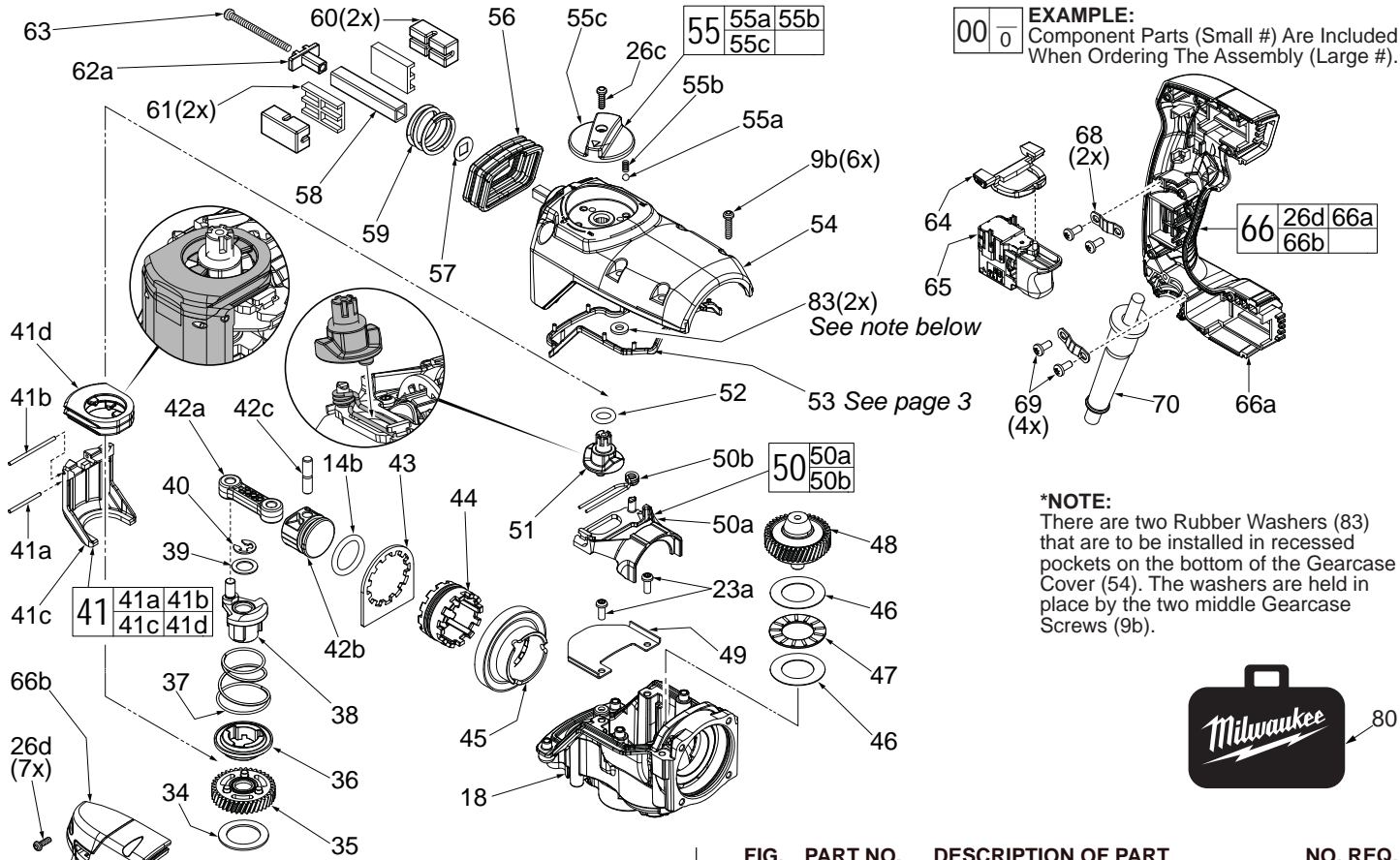

# SERVICE PARTS LIST

BULLETIN NO.  
54-24-0075

SPECIFY CATALOG NO. AND SERIAL NO. WHEN ORDERING PARTS		REVISED BULLETIN	DATE
<b>1-1/8" (3Kg) SDS Rotary Hammer</b>			Jan. 2015
CATALOG NO.	<b>5268-21</b>	WIRING INSTRUCTION <b>SEE PAGE 5</b>	
STARTING SERIAL NO.	<b>F82A</b>		



● = Component of Rotary Hammer Service Kit No. 14-46-5268 (See page three)

FIG.	PART NO.	DESCRIPTION OF PART	NO. REQ.
9b	06-75-2408	M4 x 17mm Pan Hd. Taptite T-20 w/Nylok	6
14b	34-40-0068	O-Ring (1 on Piston #42b, 1 on Ram #14a)	2
18	14-29-0067	Gearbox Assembly	1
23a	05-78-0105	M4 x 10mm Pan Hd. Taptite Screw	2
26c	06-82-2025	M3.5 x 16mm Pan Hd. Plastite T-10 Screw	1
26d	05-88-1610	M3.5 x 10mm Pan Hd. Plastite T-10 Screw	7
34	45-88-0106	Washer	1
35	32-60-0042	Crank Gear Assembly with Needle Bearing	1
36	44-90-0152	Crank Shift Ring	1
37	40-50-0107	Crank Spring	1
38	14-09-0110	Crank Assembly	1
39	44-66-0122	Crank Shim	1
40	42-70-5268	● Retaining E-Ring	1
41	14-46-0117	Chisel Shifter Assembly	1
41a	-----	M2 x 27mm Dowel Pin	1
41b	-----	M2 x 40mm Dowel Pin	1
41c	-----	Chisel Bracket	1
41d	-----	Chisel Shift Driver	1
42a	44-94-0022	Connecting Rod	1
42b	44-62-0302	Piston	1
42c	44-60-0147	Wrist Pin	1
43	44-66-0303	Locking Plate	1
44	44-90-0127	Shift Ring	1
45	32-05-0202	Bevel Gear	1
46	45-88-0112	Thrust Washer	2

FIG.	PART NO.	DESCRIPTION OF PART	NO. REQ.
47	02-50-0105	Thrust Bearing	1
48	32-10-0094	Clutch Gear Assembly	1
49	44-66-0132	Clamp Plate	1
50	14-46-0037	Fork Assembly	1
50a	-----	Fork	1
50b	-----	Fork Spring	1
51	42-90-0022	Shifting Coupler	1
52	34-40-0093	● O-Ring	1
53	42-92-0052	● Gearcase Gasket (See page three)	1
54	28-20-0182	Gearcase Cover	1
55	44-10-0057	Selector Knob Assembly	1
55a	-----	Selector Ball	1
55b	-----	Selector Spring	1
55c	-----	Selector Knob	1
56	22-90-0132	Top Grommet	1
57	45-88-0152	Vibration Washer (1 each for top & bottom AVS)	2
58	44-20-0141	Top AVS Square Guide Pipe	1
59	40-50-0211	Top AVS Spring	1
60	42-38-0077	Vibration Bumper (2 each for top & bottom AVS)	4
61	42-38-0137	Bumper Holder (2 each for top & bottom AVS)	4
62a	42-36-0032	Retaining Plate (Top AVS)	1
63	05-78-0012	M4 x 52mm Scr. (1 each for top & bottom AVS)	2
64	42-42-0053	Forward/Reverse Button	1
65	23-66-0027	On-Off Switch	1
66	14-34-0107	Handle Assembly	1
66a	-----	Left Handle Halve	1
66b	-----	Right Handle Halve	1
68	42-68-0601	Power Cord Clamp	2
69	05-78-5313	M4 x 9.5mm Pan Hd. Plastite T-15 Screw	4
70	22-64-0032	120V Power Cord Assembly	1
80	42-55-5268	Blow Molded Carrying Case	1
83	45-88-0014	● Rubber Washer	2

**MILWAUKEE ELECTRIC TOOL CORPORATION**  
13135 W. Lisbon Road, Brookfield, WI 53005  
Drwg. 2

● = Component of Rotary Hammer Service Kit No. 14-46-5268

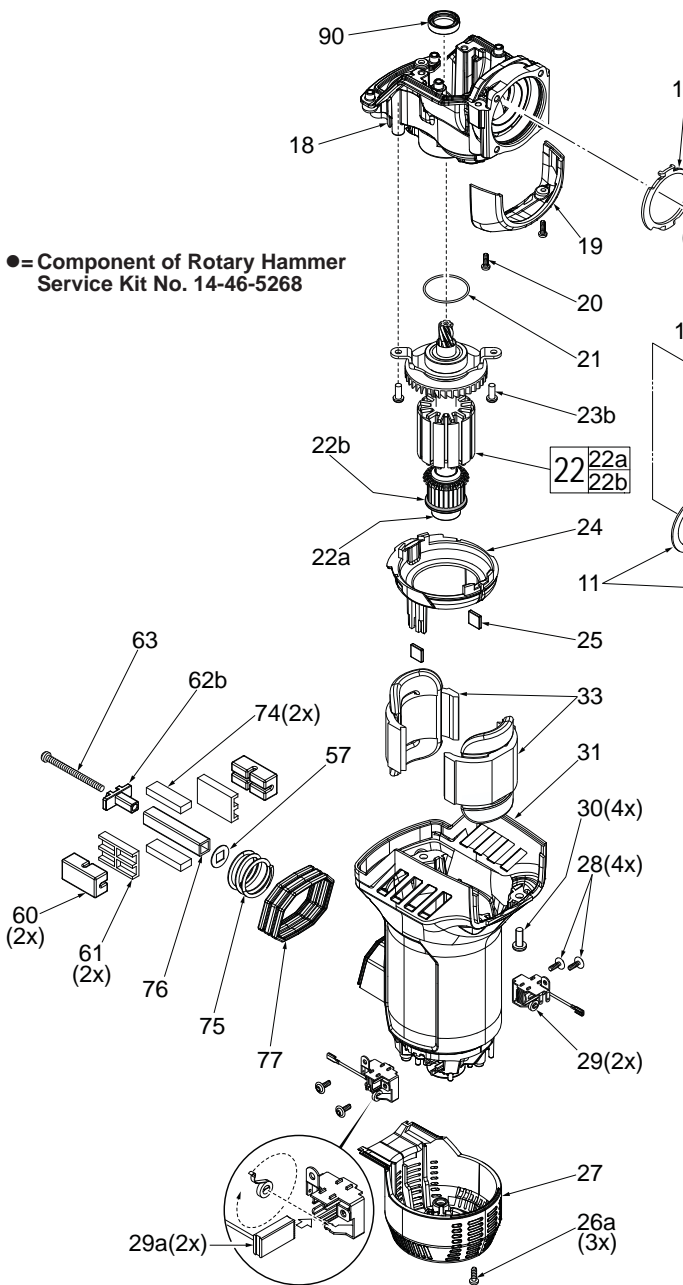

FIG.	PART NO.	DESCRIPTION OF PART	NO. REQ.
1	45-12-0045	● Dust Shield	1
2	44-90-5262	● Retaining Ring	1
3	45-22-0062	Collar with Steel Insert	1
4	02-02-0275	● 7mm Steel Ball	2
5	42-36-0017	● Ball Support Plate	1
6	40-50-0082	Conical Spring	1
7	14-34-0015	Side Handle Assembly	1
7a	44-66-0072	Clamp Collar	1
7b	05-81-5376	M8 x 53mm Screw	1
7c	-----	Side Handle Carrier Assembly	1
7f	45-88-5377	Washer	1
7g	31-05-5383	Side Handle	1
7h	44-94-5381	Depth Rod	1
8	45-22-0045	Side Handle Sleeve	1
9a	05-78-5316	M4 x 14mm Pan Hd. Taptite T-20 Screw	4
10	42-40-0027	Bushing Sleeve Assembly with Seals	1
11	45-88-0157	Washer	3
12	42-38-0127	● Bumper	2
13	14-46-0197	Spindle Assembly	1
13a	38-50-0052	Spindle	1
13b	43-06-0060	Brake Ring	1
13c	44-66-0203	Anvil Ring	1
13d	34-40-0032	● Square O-Ring	1
13e	42-06-0027	Anvil/Striker	1
13f	34-40-0052	● Anvil O-Ring	1
13g	42-06-0067	Ram Catcher	1
13h	44-90-0032	● Back Pressure Ring	1
13j	34-60-0027	● Anvil Retaining Ring	1
14a	45-56-0065	Ram	1

FIG.	PART NO.	DESCRIPTION OF PART	NO. REQ.
14b	34-40-0068	● O-Ring (1 on Ram #14a, 1 on Piston #42b)	2
15	42-76-0037	Spindle Collar	1
16	34-40-0082	● O-Ring	1
17	44-60-0119	Retaining Plate	1
18	14-29-0067	Gearbox Assembly	1

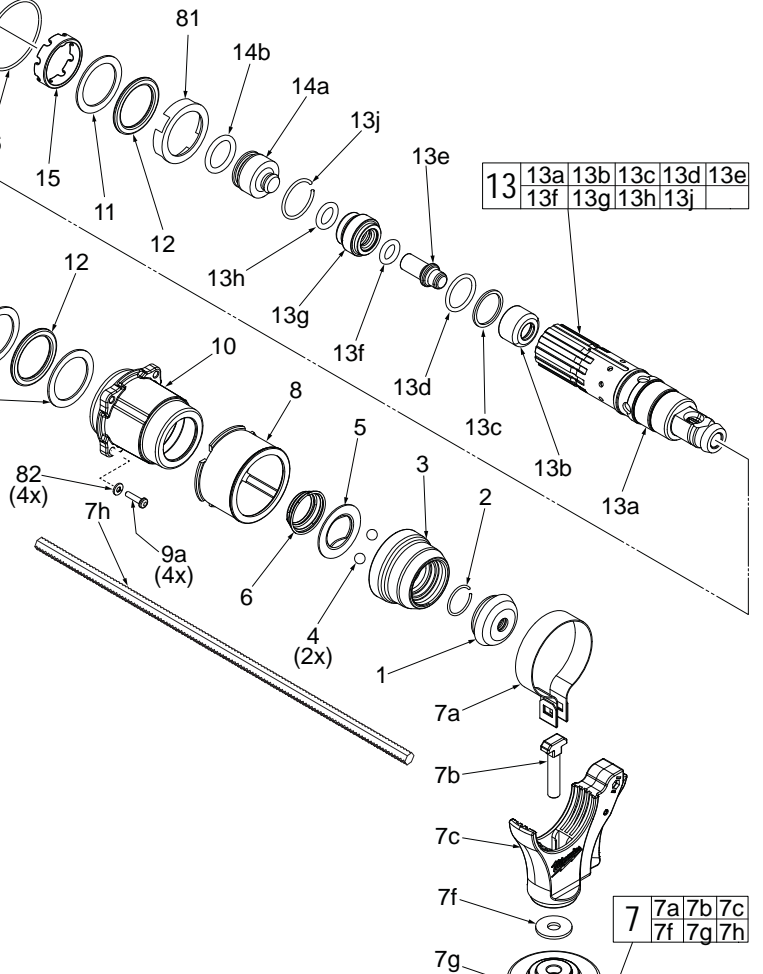
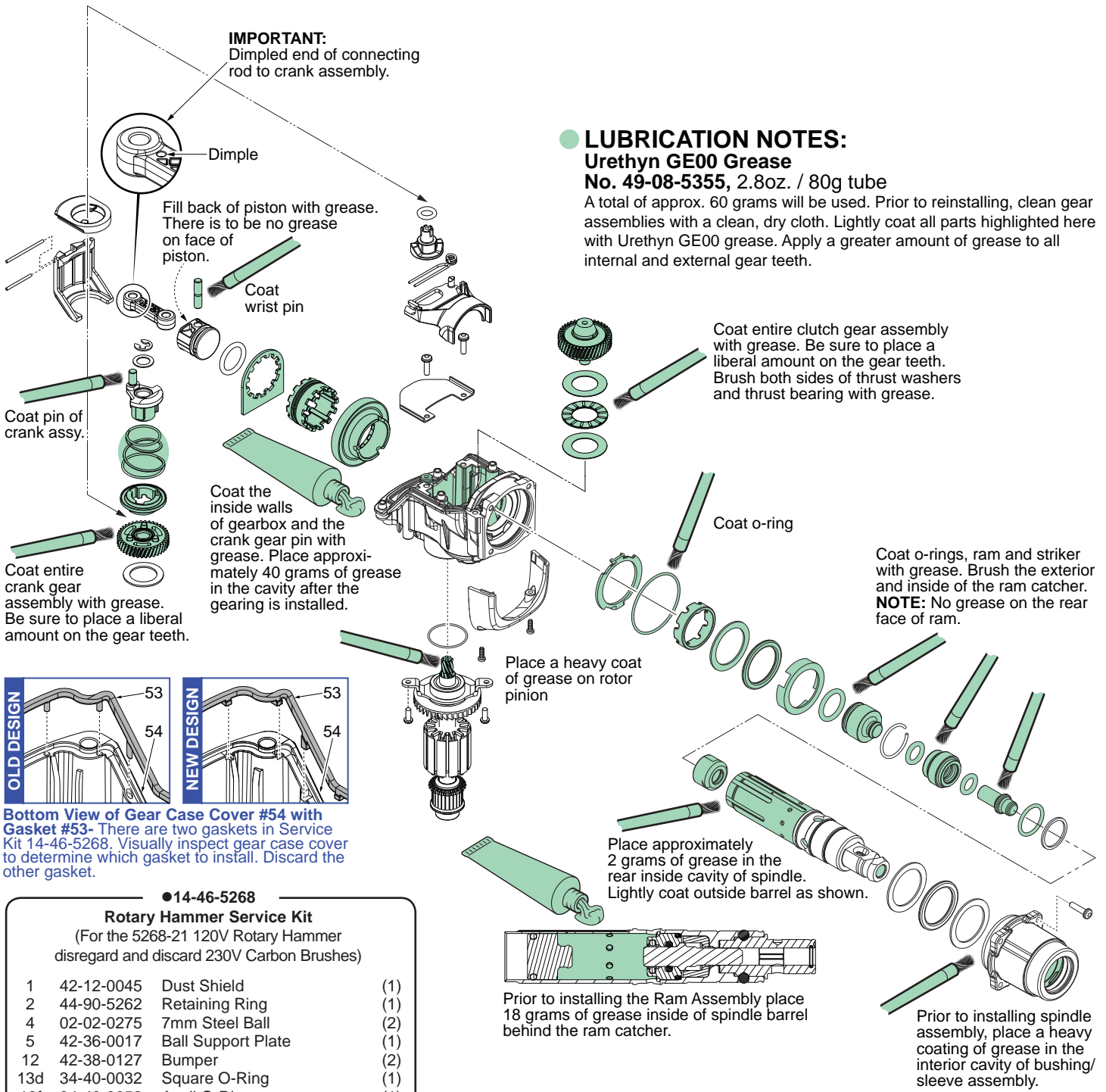

FIG.	PART NO.	DESCRIPTION	NO. REQ.
19	31-15-0039	Shroud	1
20	05-86-1000	M3 x 9.5mm Pan Hd. Tapt. T-10 Scr.	2
21	34-40-5320	● O-Ring	1
22	14-50-0052	120V Armature Assembly	1
22a	02-04-5382	Ball Bearing	1
22b	23-16-0092	Commutator Insulator Disc	1
23b	05-78-0105	M4 x 10mm Pan Hd. Taptite Screw	2
24	31-05-0057	Baffle	1
25	42-28-0085	Field Isolation Block	2
26a	05-88-1610	M3.5 x 10mm Pan Hd. Plastite T-10 Screw	3
27	23-44-0063	Motor Housing/Brush Cover	1
28	06-82-0062	M3 x 8mm Pan Hd. Washer T-10 Screw	4
29	22-20-0019	120V Carbon Brush Assembly	2
29a	22-18-5268	● 120V Carbon Brush (Set of 2)	1
30	05-74-0990	M5 x 15mm Pan Hd. Taptite T-25 Screw	4
31	28-50-0107	Motor Housing Assembly	1
33	18-07-0097	120V Split Field	1
57	45-88-0152	Vibration Washer	2
60	42-38-0077	Vibration Bumper	4
61	42-38-0137	Bumper Holder	4
62b	44-66-0131	Retaining Plate (Bottom AVS)	1
63	05-78-0012	M4 x 52mm Scr. (1 each for top & bottom AVS)	2
74	44-52-0052	Foam Block	2
75	40-50-0138	Bottom AVS Spring	1
76	44-68-0155	Bottom AVS Square Guide Pipe	1
77	22-90-0152	Bottom Grommet	1
78	12-20-5268	Service Nameplate (Not Shown)	1
81	45-88-0042	Bumper/Washer Holder	1
82	05-90-0225	Lock Washer	4
90	45-06-0042	Motor Seal	1



**LUBRICATION NOTES:**

**Urethyn GE00 Grease**  
**No. 49-08-5355, 2.8oz. / 80g tube**

A total of approx. 60 grams will be used. Prior to reinstalling, clean gear assemblies with a clean, dry cloth. Lightly coat all parts highlighted here with Urethyn GE00 grease. Apply a greater amount of grease to all internal and external gear teeth.

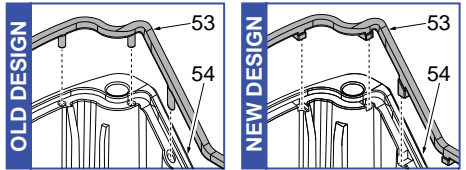

**Bottom View of Gear Case Cover #54 with Gasket #53-** There are two gaskets in Service Kit 14-46-5268. Visually inspect gear case cover to determine which gasket to install. Discard the other gasket.

●14-46-5268

**Rotary Hammer Service Kit**

(For the 5268-21 120V Rotary Hammer disregard and discard 230V Carbon Brushes)

1	42-12-0045	Dust Shield	(1)
2	44-90-5262	Retaining Ring	(1)
4	02-02-0275	7mm Steel Ball	(2)
5	42-36-0017	Ball Support Plate	(1)
12	42-38-0127	Bumper	(2)
13d	34-40-0032	Square O-Ring	(1)
13f	34-40-0052	Anvil O-Ring	(1)
13h	44-90-0032	Back Pressure Ring	(1)
13j	34-60-0027	Anvil Retaining Ring	(1)
14b	34-40-0068	O-Ring	(2)
16	34-40-0082	O-Ring	(1)
21	34-40-5320	O-Ring	(1)
29a	22-18-5268	120V Carbon Brush (Set of 2)	(1)
		For model 5268-21.	
29a	22-18-5269	230V Carbon Brush (Set of 2)	(1)
		For model 5268-50. <b>DISCARD</b>	
40	42-70-5268	Retaining E-Ring	(1)
52	34-40-0093	O-Ring	(1)
53	42-92-0052	Gearcase Gasket (See detail above)	(1)
53	42-92-0053	Gearcase Gasket (See detail above)	(1)
83	45-88-0014	Rubber Washer	(2)
	58-22-5268	Instruction Sheet	(1)
	49-08-5355	Urethyn GE00 Grease	
		60 grams required-	
		(80 gram, 2.8oz tube)	(1)

**NOTE:** It is recommended to order Motor Seal #90 (45-06-0042) at the same time that Rotary Hammer Service Kit No. 14-46-5268 is installed.

**SCREW TORQUE SPECIFICATIONS**

FIG.	PART NO.	WHERE USED	SEAT TORQUE	
			(KG/CM)	(IN/LBS)
9a	05-78-5316	Bushing Sleeve Assembly	26	22.5
9b	06-75-2408	Gearcase Cover (4) Rear and Middle	32	27.8
9b	06-75-2408	Gearcase Cover (2) Front	32	27.8
20	05-86-1000	Shroud	12	10.5
23a	05-78-0105	Clamp Plate	26	22.5
23b	05-78-0105	Rotor Bearing Plate	33	28.5
26a	05-88-1610	Motor Housing/Brush Cover	6.5	5.5
26c	06-82-2025	Selector Knob	8.5	7.5
26d	05-88-1610	Right Handle Halve	6.5	5.5
28	06-82-0062	Carbon Brush Assembly	5	4.5
30	05-74-0990	Motor Housing Assembly	33	28.5
63	05-78-0012	Retaining Plate (Top and Bottom)	20	17
69	05-78-5313	Cord Clamps (Power Cord)	14	12
69	05-78-5313	Cord Clamps (Glass Fiber Tube)	11	9.5
		Switch Screws	5.5	4.5

**NOTE:** As an aid to working on the gearcase and spindle assemblies, a bench top fixture can be made from a 3.25" piece of 4" PVC pipe. The contour of the pipe can be cut according to dimensions in the illustration.

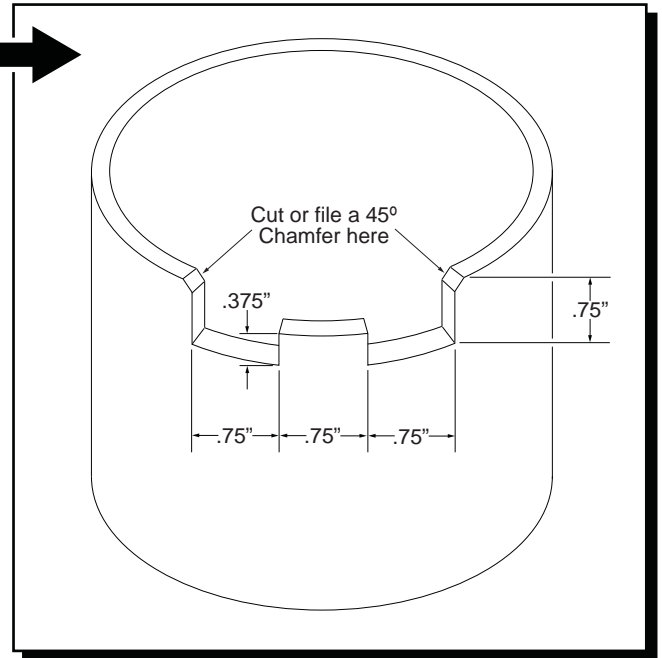

**SERVICE TOOLS:**

**61-10-0041**  
Ring Expander  
Cone

**61-10-0043**  
Push Sleeve

**61-10-0045**  
Seal Press Pin

**61-10-0049**  
Anvil Sleeve  
Snap Ring Bar

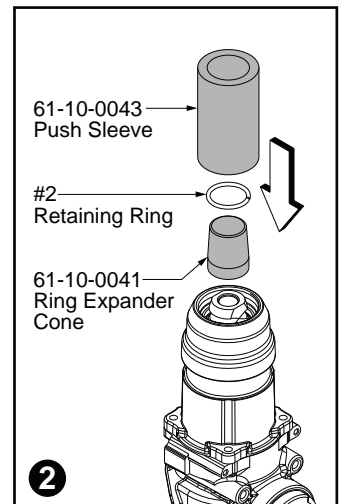
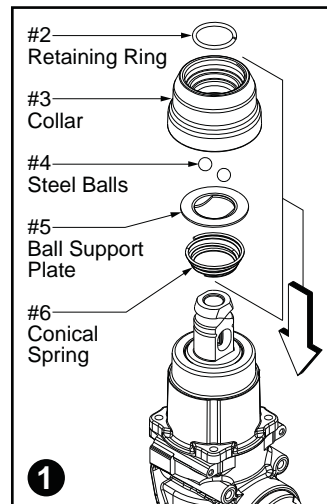
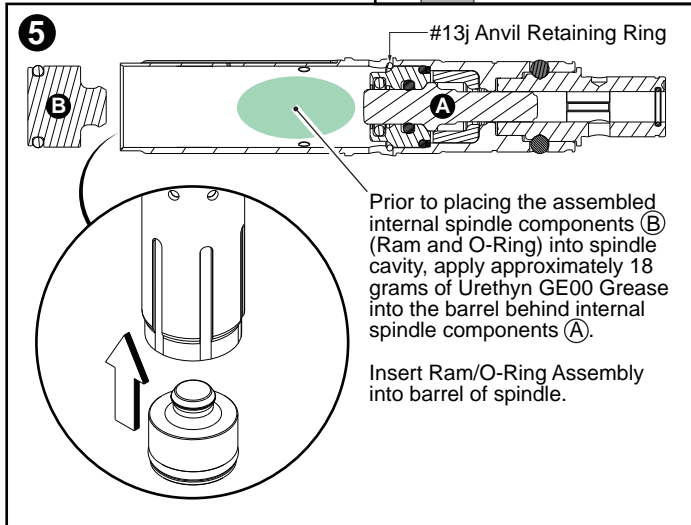
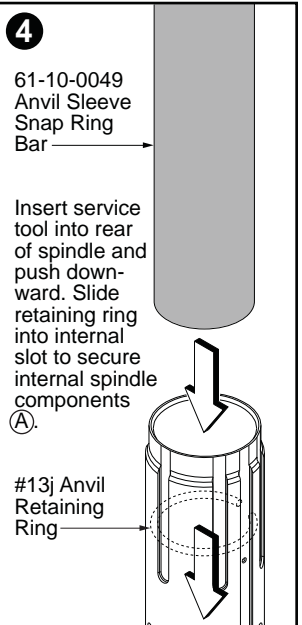
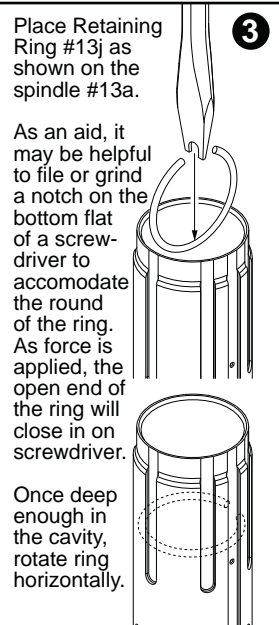
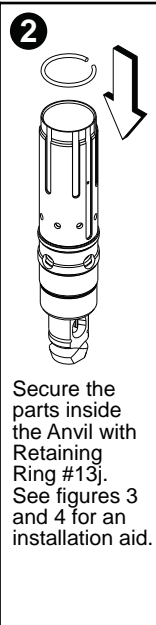
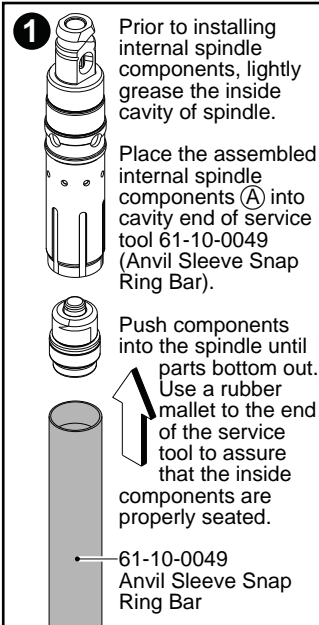
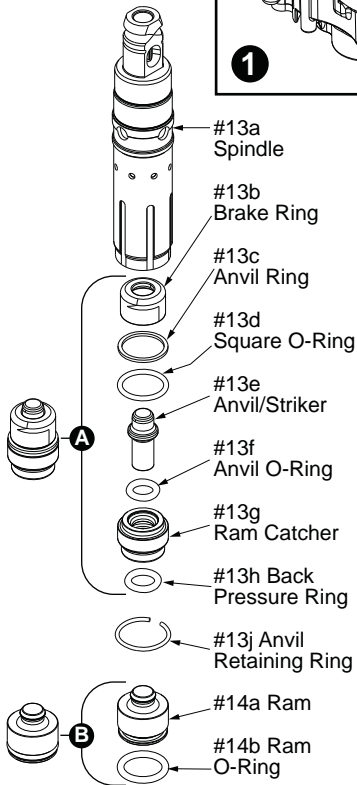
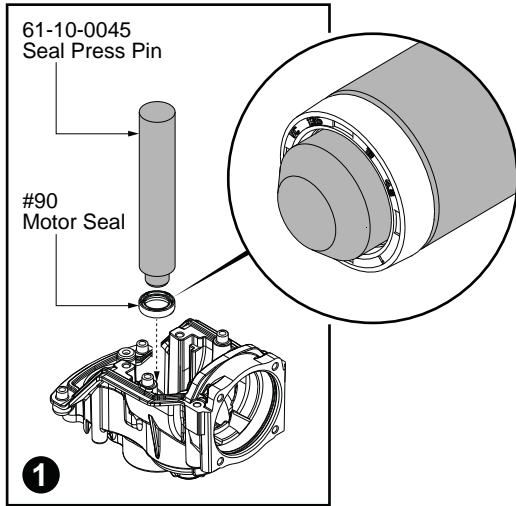

AS AN AID TO REASSEMBLY, TAKE NOTICE OF WIRE ROUTING AND POSITION IN WIRE GUIDES AND TRAPS WHILE DISMANTLING TOOL.

BE CAREFUL AND AVOID PINCHING WIRES BETWEEN HANDLE HALVES WHEN ASSEMBLING.

It is recommended that a .75" piece of heat shrink tubing be used to contain wires #3 & #4 at the right side of the switch. Do the same for wires #5 & #6 on the other side.

Insulated sleeving to extend .25 min. beyond clamp area.

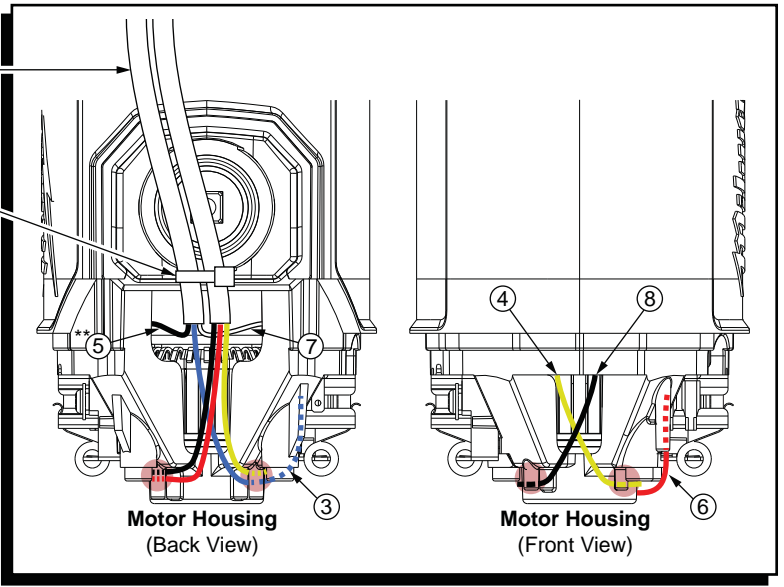
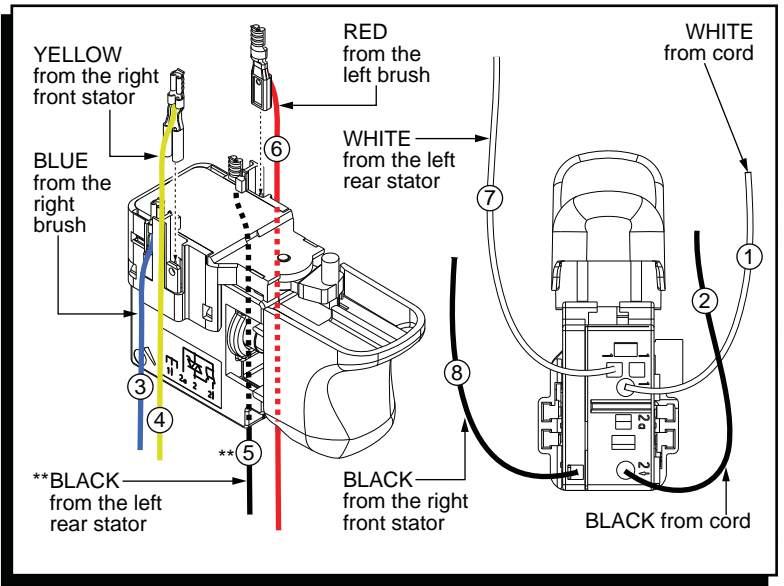
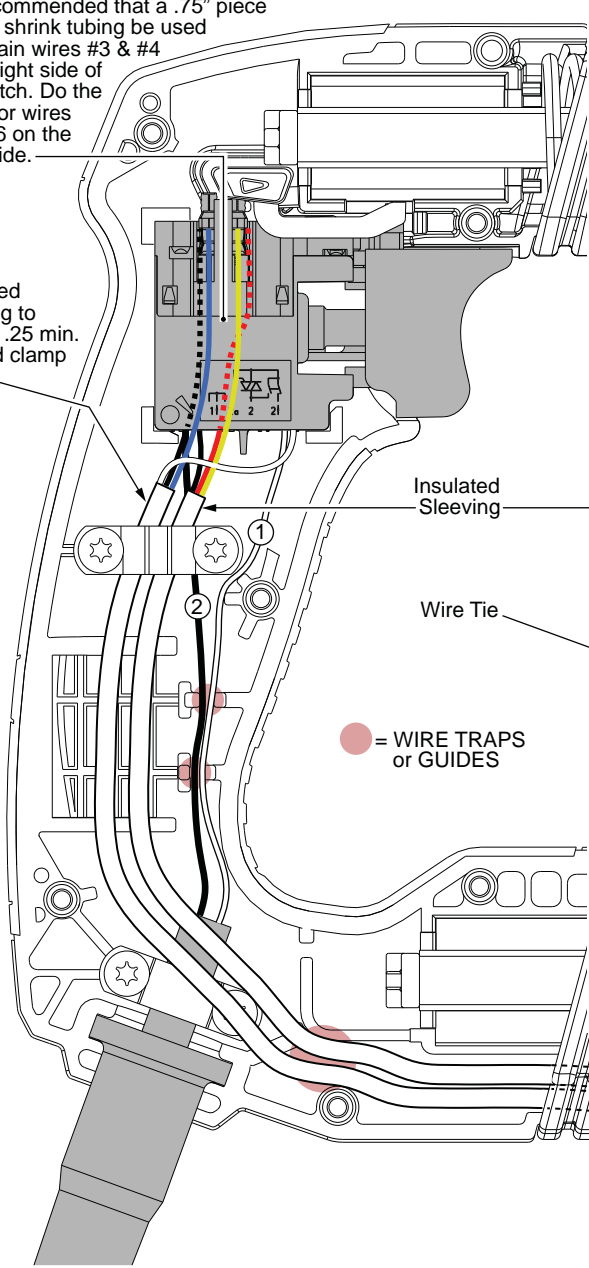

**\*\* TO AVOID CONFUSION, PLEASE NOTE:**  
The insulation color for field wire #5 is BLACK. Early production of the field used in the 5268-21 Hammer had green insulation on wire #5 or used black heat shrink tubing over the green insulation.

WIRING SPECIFICATIONS				
Wire No.	Wire Color	Origin or Gauge	Length	Terminals, Connectors and 1 or 2 End Wire Preparation
1	White	22-64-0032	-----	Component of cord set. Connect to position 1↓ on bottom of switch as shown.
2	Black	22-64-0032	-----	Component of cord set. Connect to position 2↓ on bottom of switch as shown.
3	Blue	23-94-0072	-----	Blue Leadwire Assembly. Connect to position 7 on switch and left brush holder as shown.
4	Yellow	18-07-0097	-----	Component of split field (front halve). Connect to position 6 on switch as shown.
5	Black**	18-07-0097	-----	Component of split field (rear halve). Connect to position 5 on switch as shown.
6	Red	23-94-0062	-----	Red Leadwire Assembly. Connect to position 8 on switch and right brush holder as shown.
7	White	18-07-0097	-----	Component of split field (rear halve). Connect to position 1 on the bottom of switch as shown.
8	Black	18-07-0097	-----	Component of split field (front halve). Connect to position 2 on bottom of switch as shown.